

Read all instructions BEFORE assembly and USE of product. KEEP INSTRUCTIONS FOR FUTURE USE

**\*IMPORTANT, RETAIN FOR FUTURE REFERENCE\***  
**PLEASE READ CAREFULLY**

**Boori International**

AUSTRALIA  
 18-20 Charles Street  
 St. Marys Sydney NSW  
 2760 Australia  
 Ph: 61 2 9833 3769  
 Fax: 61 2 9673 4240



Boori (UK) Ltd  
 Unit 1, Transigo,  
 Gables Way, Kennet Park,  
 Thatcham, Berkshire,  
 RG19 4ZA  
 Ph: (44) 016 3529 5670  
 Fax: (44) 016 3587 7552

Boori USA LLC  
 20 Chapin Road, Ste 1001  
 Pine Brook, NJ 07058  
 Ph: +1 973 577 6933  
 Fax: +1 973 577 6934

Boori JAPAN Co., Ltd  
 401A, 4-2-10 Kitakyuhoji-machi,  
 Chuo-ku, Osaka 541-0057 Japan  
 TEL: 06-4963-3939  
 FAX: 06-4963-3900  
 E-mail: info@boori.co.jp

**Instructions for the Boori Country USA NEWPORT CRIB FOREVER**

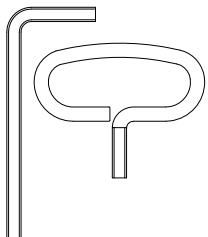
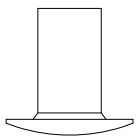
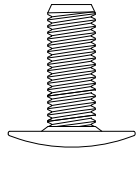
Hardware and parts list

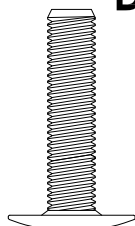
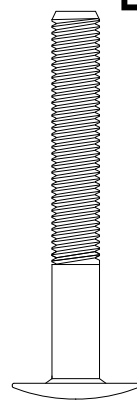
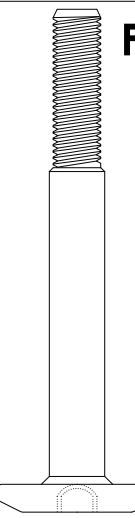
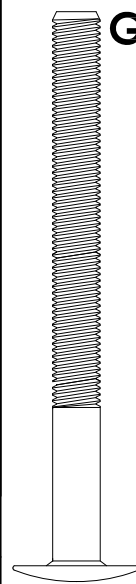
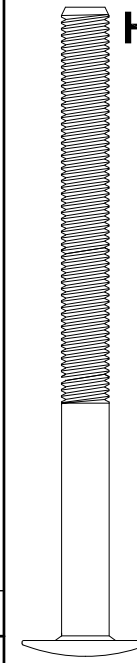
2 x Allen Keys	6 x M6*14mm Capping nuts	2 x M6*18mm Connecting bolts	2 x Ø8*30mm Wooden dowels	4 x M6*28mm Connecting bolts	4 x M6*54mm Connecting bolts	3 x M6*60mm Connecting bolts	4 x M6*70mm Connecting bolts	4 x M6*80mm Connecting bolts
	 Preassembled	 Actual size		 Preassembled	 Actual size	 Actual size	 Actual size	 Actual size

1x Cap of headboard

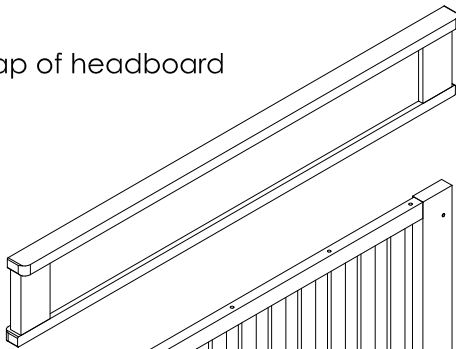

1x Headboard

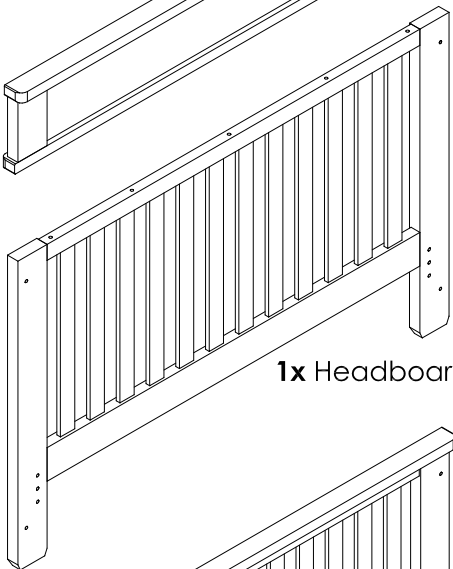

1 x Footboard

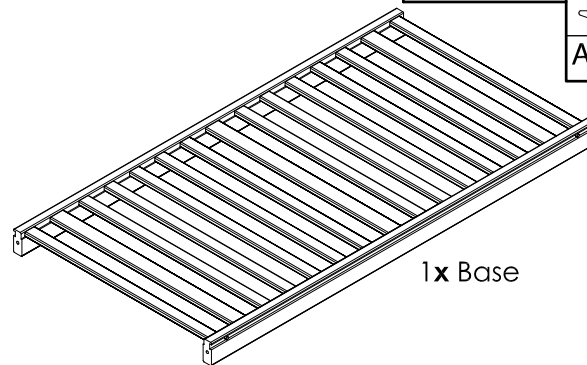
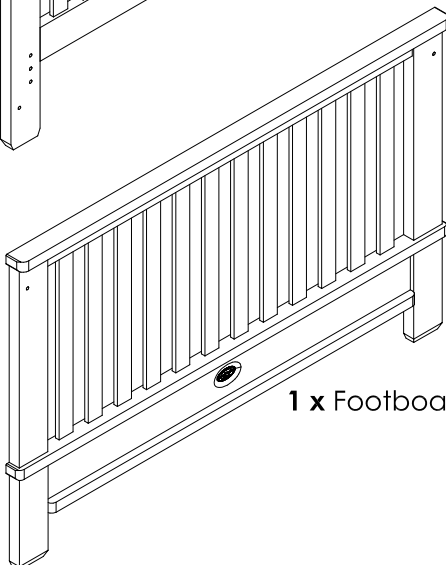

1x Base

A+D  
 (Preassembled)

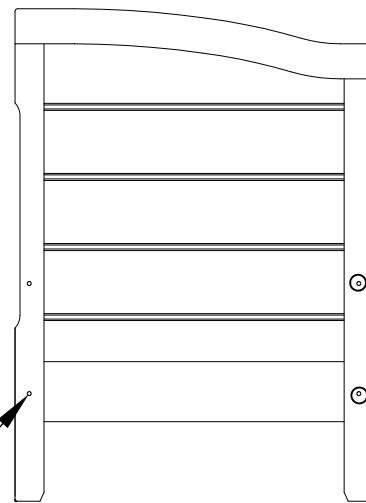

2 x Side Panel (Identical)

⊙ **Top Hole**  
 (For high base position)

⊙ **Bottom Hole**  
 (For low base position)

# Assembly as a Crib

Stage 1: Cap of headboard on to the headboard and then screw 3 X F Connecting bolts and 2XC Wooden dowels

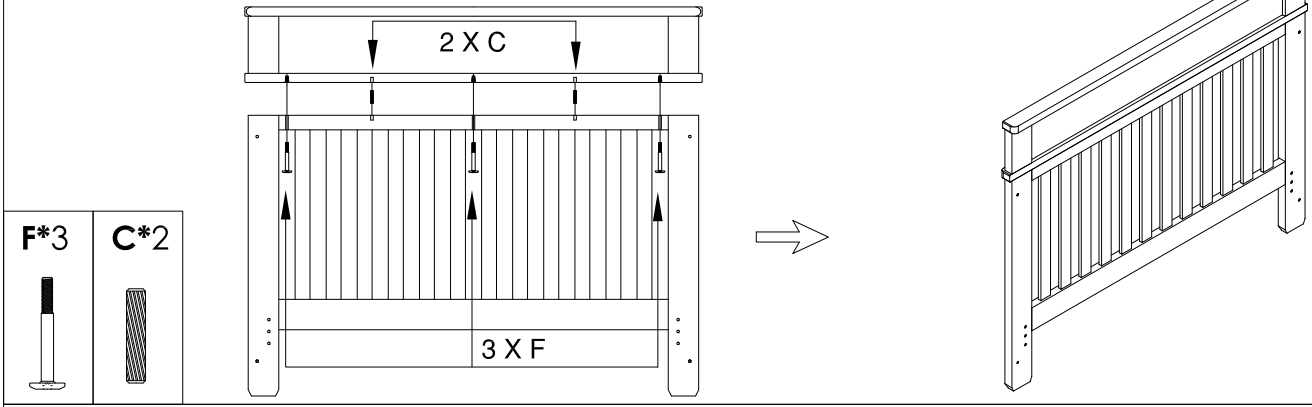

Stage 2: Connect Headboard panel to the two side panels with the 2 XE and 2XH connecting bolts provided. tighten all the connecting bolts (Do not over tighten)

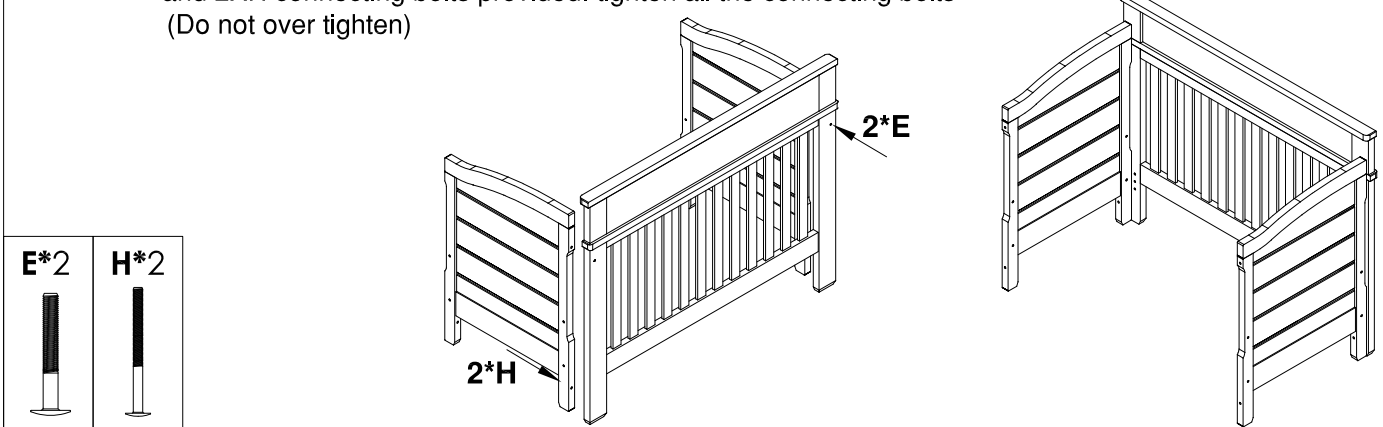

Stage 3: Connect mattress base to the two side panels with the 4 XG connecting bolts provided.

Note: **Top Hole** for the newborn position  
**Bottom Hole** for baby position.

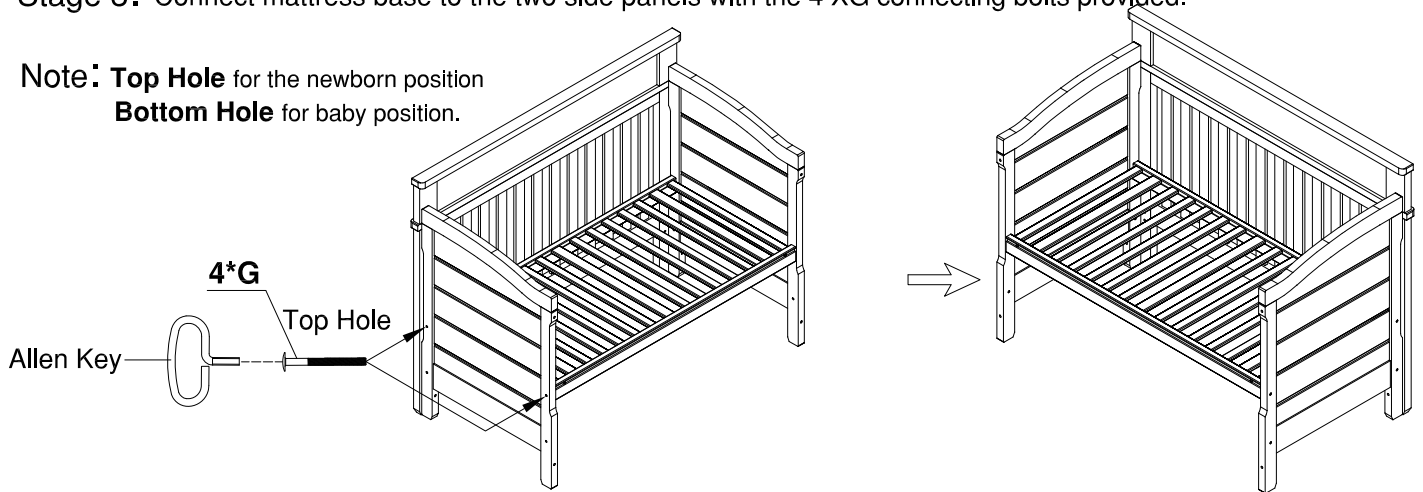

Stage 4: Connect Footboard to the two side panels with the 2 XE and 2XH connecting bolts provided. tighten all the connecting bolts (Do not over tighten)

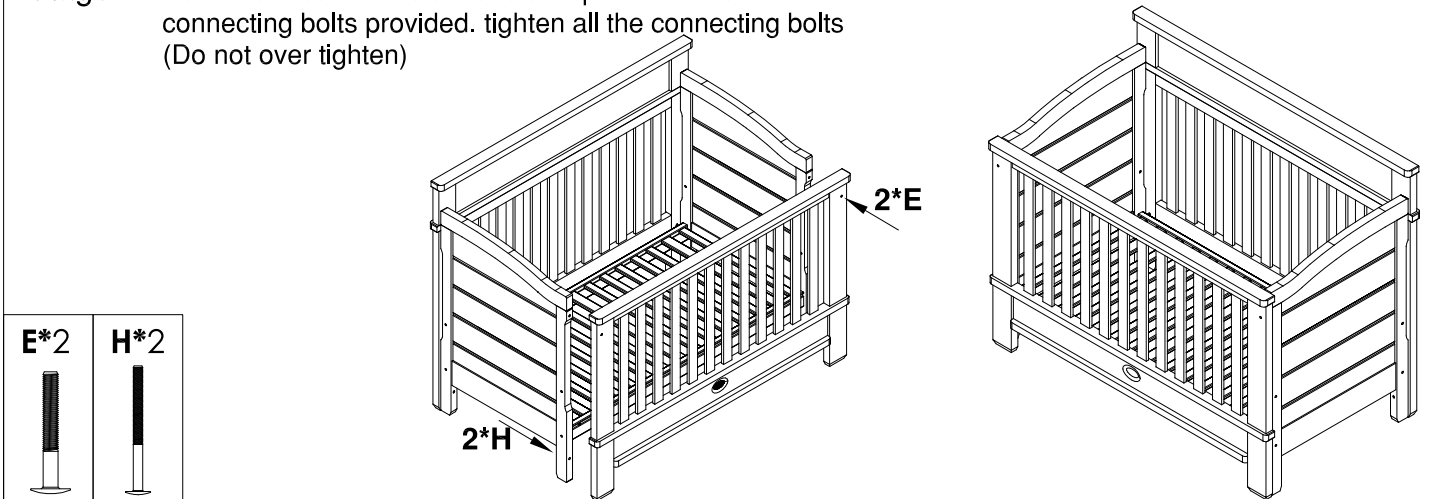

# Assembly as a Crib

**Note:** When child is able to sit up adjust mattress/base to the lower position (bottom hole) and remove bumper pads, large toys and other objects that could serve as steps for climbing out.

Remove 4\*(A+D) preassembled from the bottom holes of side panels and block top holes with 4\*D connecting bolts and 4\*A capping nuts provided.

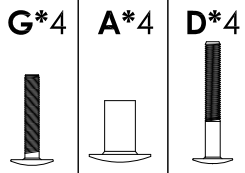
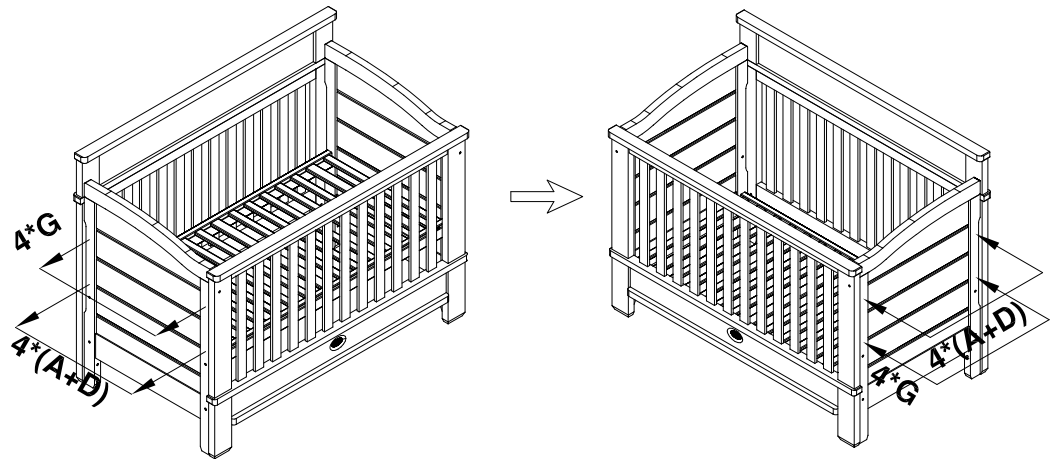

# Converting to the Day Bed

**Stage 1:** Reposition the base to the lower position (bottom hole of Footboard)  
Screw all bolts loose and remove two fixed sides

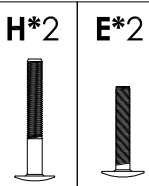
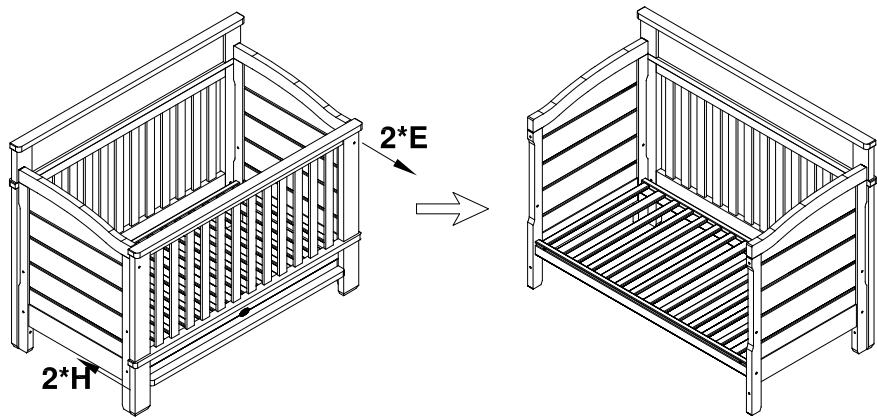

**Stage 2:** Block the top holes with the 2\*E connecting bolts and 2\*A capping nuts provided  
Block remaining holes on the side panel with 2\*B connecting bolts

