

Read all instructions BEFORE assembly and USE of product. KEEP INSTRUCTIONS FOR FUTURE USE

**\*IMPORTANT, RETAIN FOR FUTURE REFERENCE\***  
**PLEASE READ CAREFULLY**

Boori International

AUSTRALIA  
 18-20 Charles Street  
 St.Marys Sydney NSW  
 2760 Australia  
 Ph: 61 2 9833 3769  
 Fax: 61 2 9673 4240

Boori (UK) Ltd  
 Unit 1, Transigo,  
 Gables Way, Kennet Park,  
 Thatcham, Berkshire,  
 RG19 4ZA  
 Ph: (44) 016 3529 5670  
 Fax: (44) 016 3587 7552

Boori USA LLC  
 20 Chapin Road, Ste 1001  
 Pine Brook, NJ 07058  
 Ph: +1 973 577 6933  
 Fax: +1 973 577 6934

Boori JAPAN Co., Ltd  
 401A, 4-2-10 Kitakyuhoji-machi,  
 Chuo-ku, Osaka 541-0057 Japan  
 TEL: 06-4963-3939  
 FAX: 06-4963-3900  
 E-mail: info@boori.co.jp

**Instructions for the Boori Country USA NEWPORT CRIB 3 IN 1**

Hardware and parts list

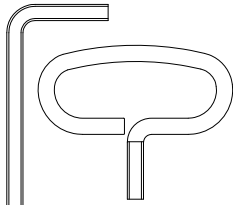
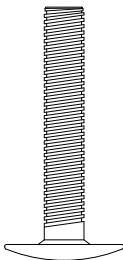
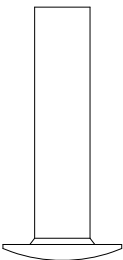
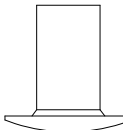
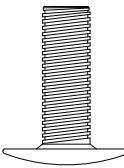
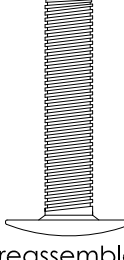
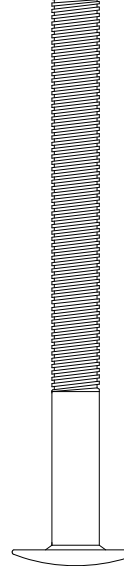
2 x Allen Keys <b>A</b>	4 x M5*30mm Connecting bolts <b>B</b>	4 x M5*30mm Capping nuts <b>C</b>	4 x M6*14mm Capping nuts <b>D</b>	8 x M6*18mm Connecting bolts <b>E</b>	4 x M6*28mm Connecting bolts <b>F</b>	12 x M6*70mm Connecting bolts <b>G</b>
			 Preassembled	 Actual size	 Preassembled Actual size	 Actual size

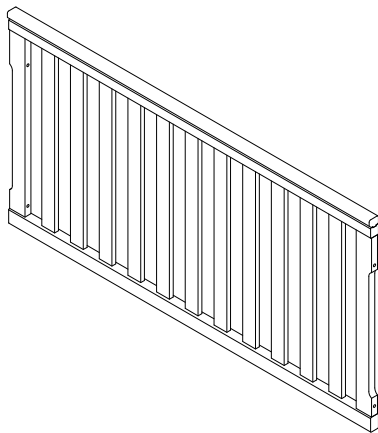

2 x Fixed Sides (Identical)

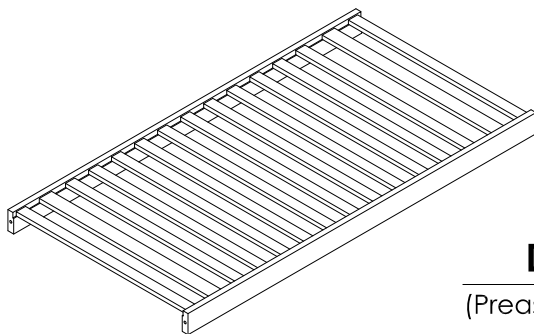

1 x Base

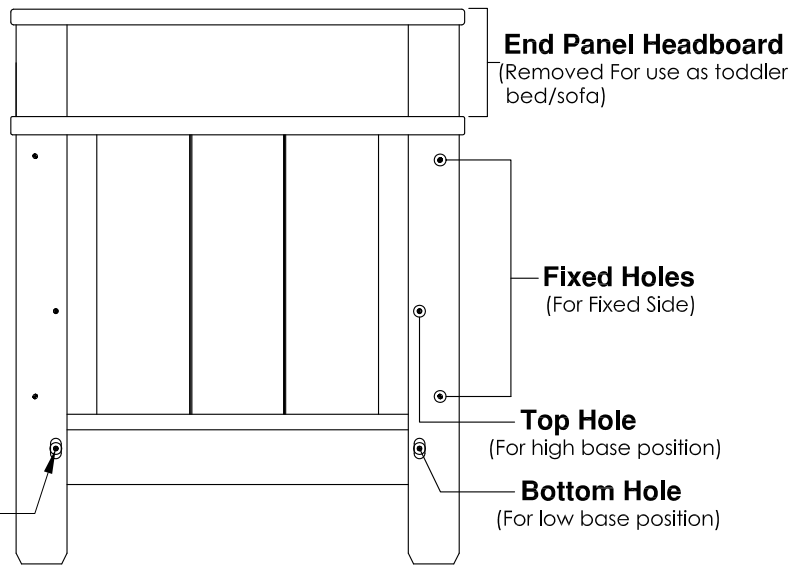

2 x End Panels (Identical)

# Assembly as a Crib

**Stage 1:** Connect one fixed side panel to the two end panels with the 4\*G connecting bolts provided.  
(Do not tighten at this stage).

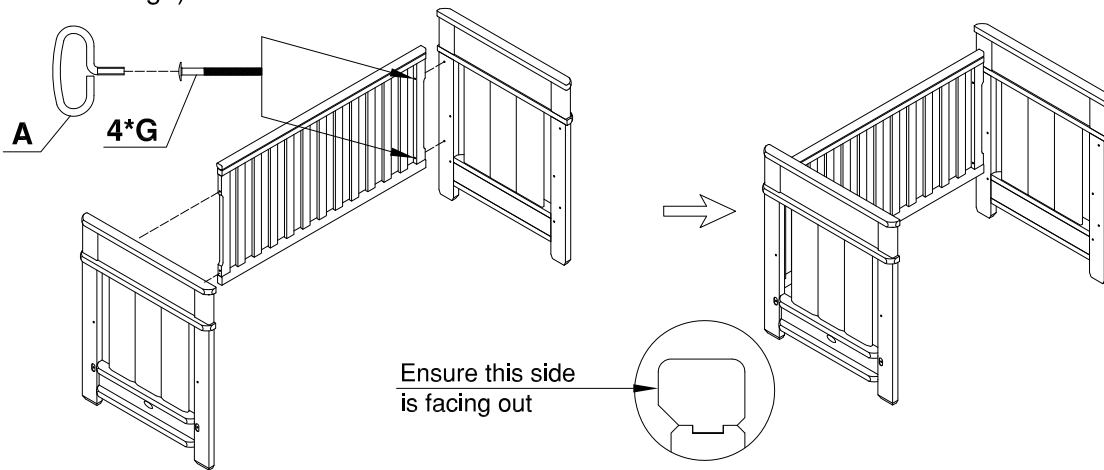

**Stage 2:** Connect mattress base to the two end panels with the 4\*G connecting bolts provided  
(Keep all bolts loose at this stage).

**Note:** Top Hole for the newborn position  
Bottom Hole for baby position

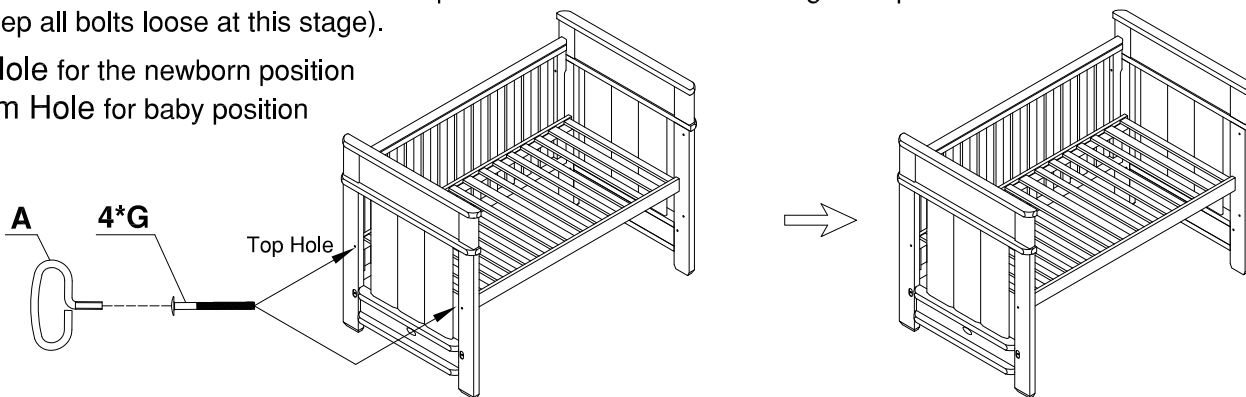

**Stage 3:** Connect another fixed side panel to the two end panels with the 4\*G connecting bolts provided.  
tighten all the connecting bolts  
(Do not over tighten)

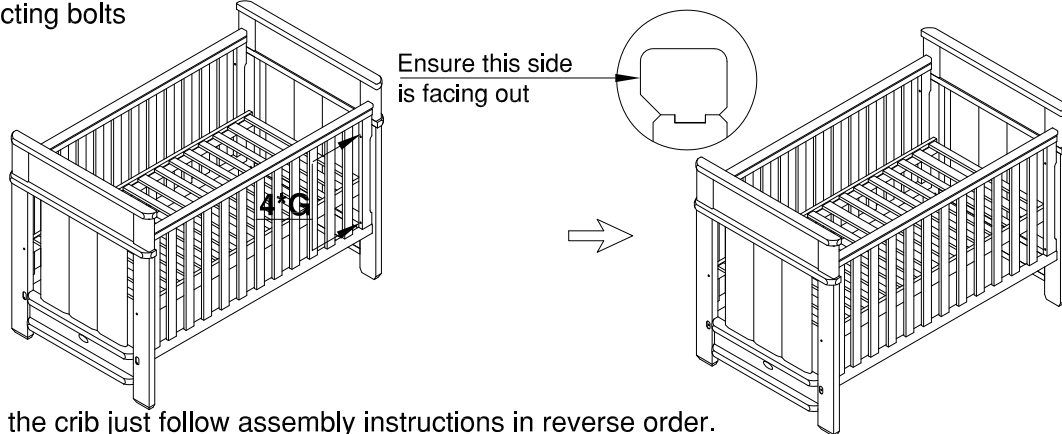

**Note:** To disassemble the crib just follow assembly instructions in reverse order.

**Note:** When child is able to sit up adjust mattress/base to the lower position (bottom hole) and remove bumper pads, large toys and other objects that could serve as steps for climbing out.

Remove 4\*(F+D) preassembled from the bottom holes of end panels and block top holes with 4\*F connecting bolts and 4\*D capping nuts provided.

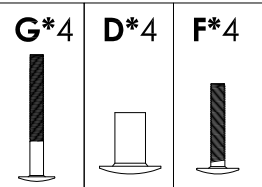
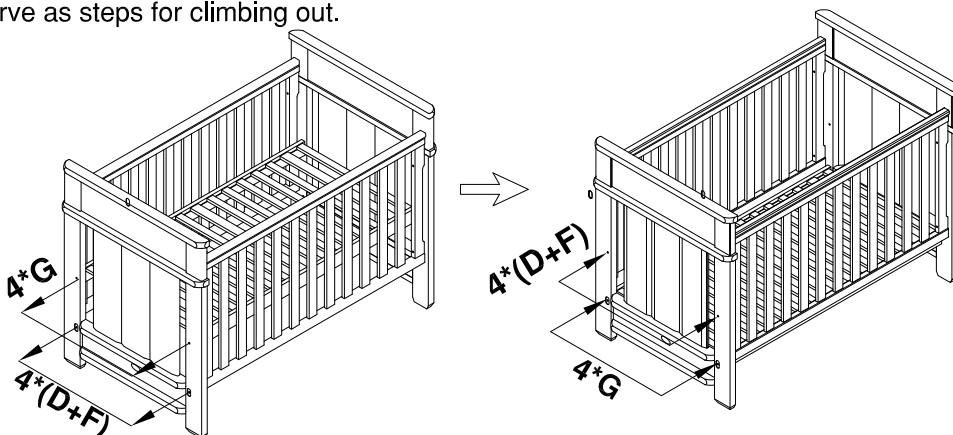

# Converting to the Toddler Bed

## Stage 1:

Reposition the base to the lower position (bottom hole of end panels)  
Screw all bolts loose and remove two fixed sides

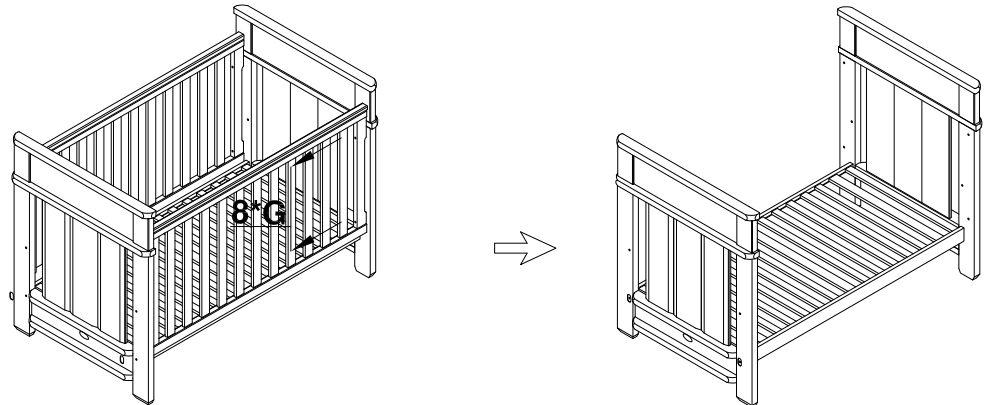

## Stage 2:

Remove headboard from one end panel.

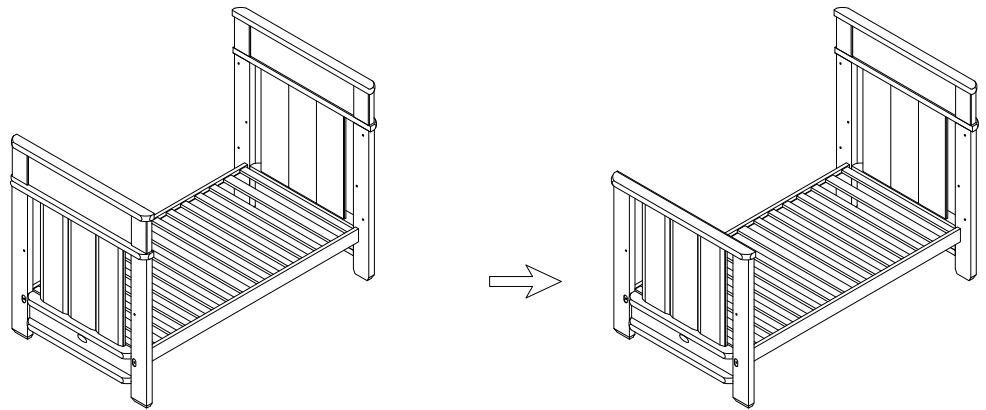
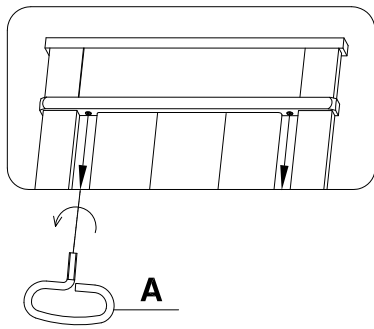

## Stage 3:

Block the top holes with the 2B、4\*F connecting bolts and 2C、4\*D capping nuts provided  
Block remaining holes on two end panels with 8\*E connecting bolts  
Tighten all the connecting bolts (Do not over tighten)

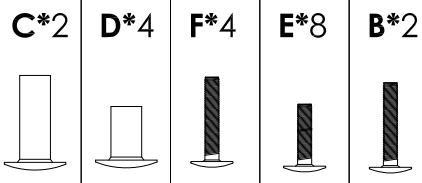
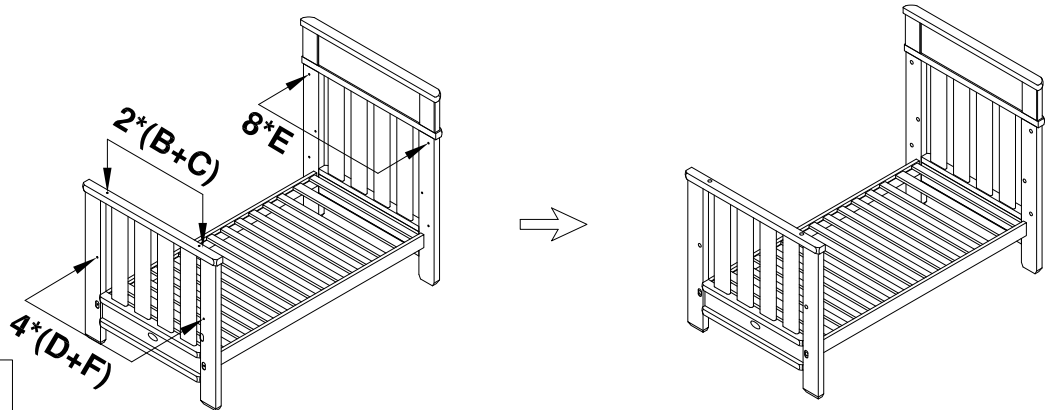

# Converting to the Day Bed

## Stage 1:

Reposition the base to the lower position (bottom hole of end panels)  
Screw all bolts loose and remove two fixed sides

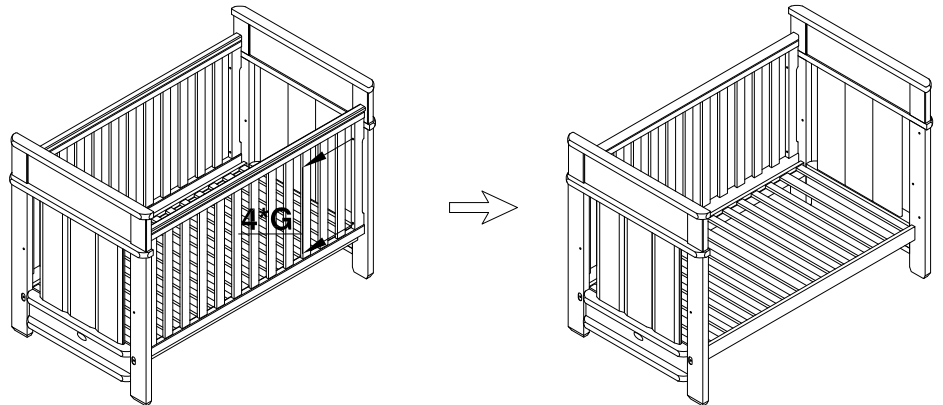

## Stage 2:

Remove two headboards from two end panels.

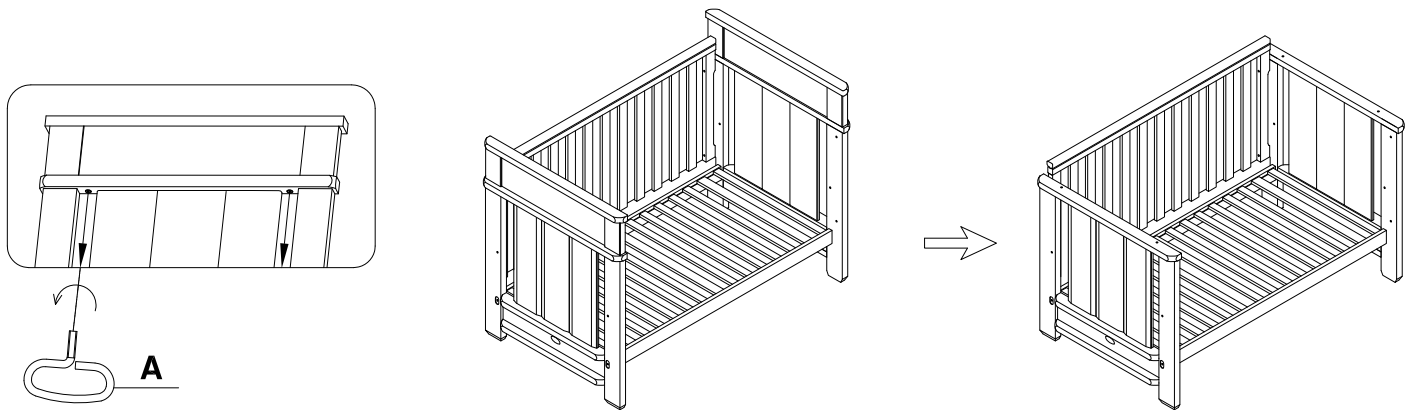

## Stage 3:

Block the top holes with the 4\*B 、 4F connecting bolts and 4C、 4\*D capping nuts provided  
Block remaining holes on the end panel with 4\*E connecting bolts  
Tighten all the connecting bolts (Do not over tighten)

